

ALL DIMENSIONS ARE IN MM.

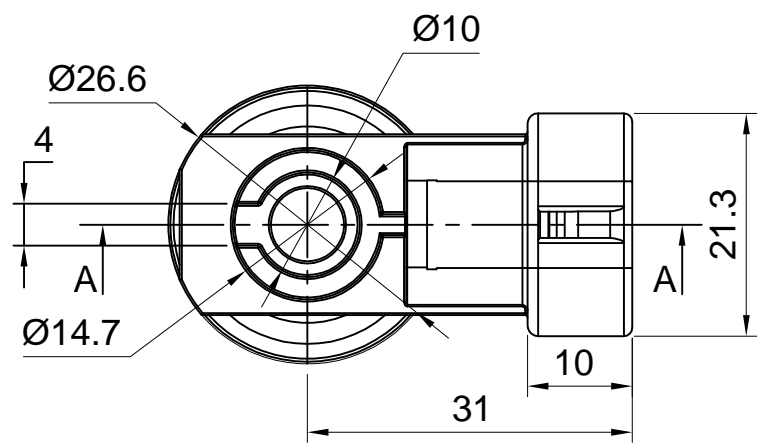

TOP VIEW

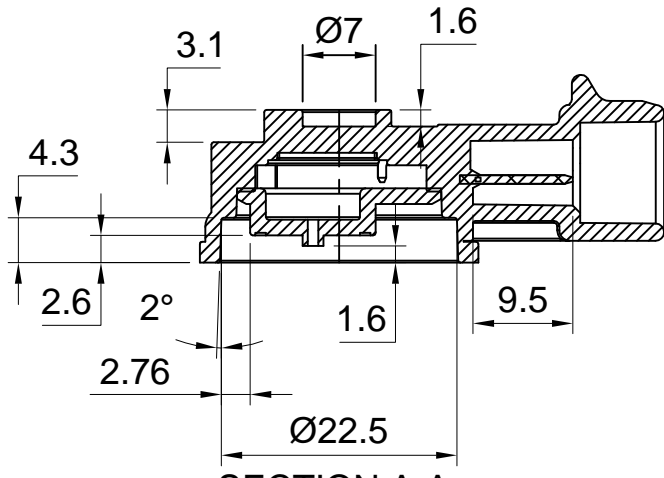

SECTION A-A

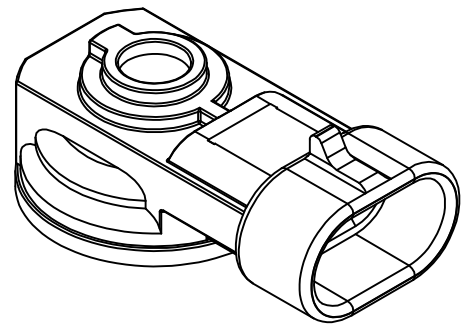

ISOMETRIC VIEW

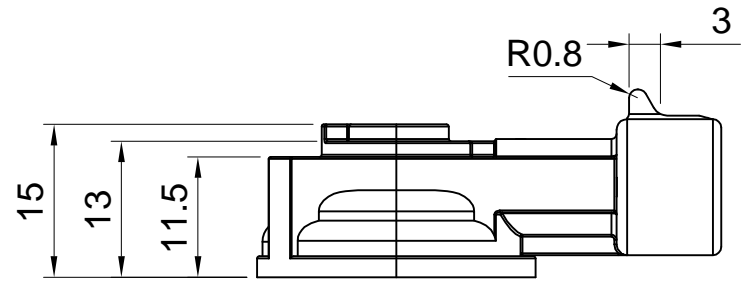

FRONT VIEW

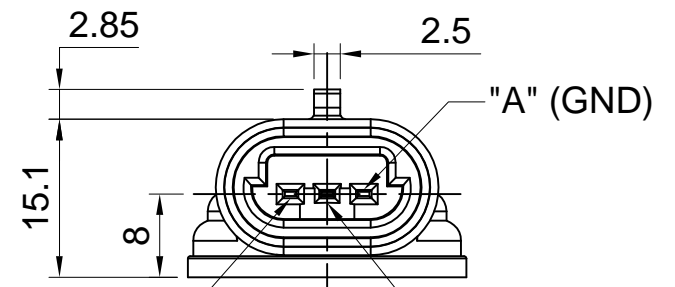

SIDE VIEW

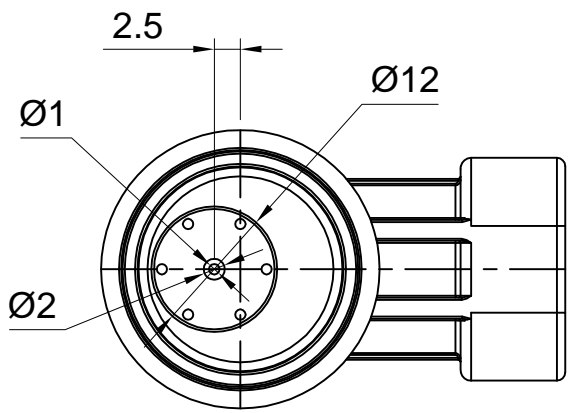

Pressure single "B" "C" Input (+)



BOTTOM VIEW

NOTE:-  
Mating connector for MAP sensor is:  
**Delphi Metri-Pack 12162185-B**

UNI-AUTOMATION (I) PVT LTD TEL/FAX:+91-(020)-24420890 www.uniautomation.com		MANIFOLD ABSOLUTE PRESSURE SENSOR	
DATE:- 29-11-2017	SCALE:- 1:1	MODEL MAP(212)	
TOLERANCES DIN-ISO 2768-1 (1991-06) (TOLERANCE CLASS-MEDIUM)	UAPL PART NO <b>199212</b>	CUSTOMER DRAWING REF NO NA	REV - 00
		CUSTOMER : STD	SHEET 1of2

IDEAL   
 HIGHER   
 LOWER 

PRESSURE VS OUTPUT

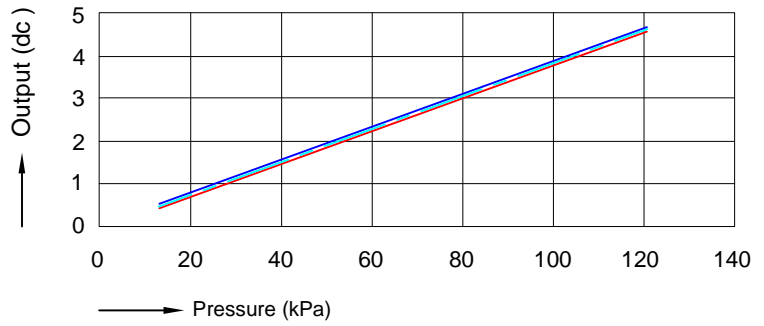

Ratiometric error (kPa)

%Error vs Temperature

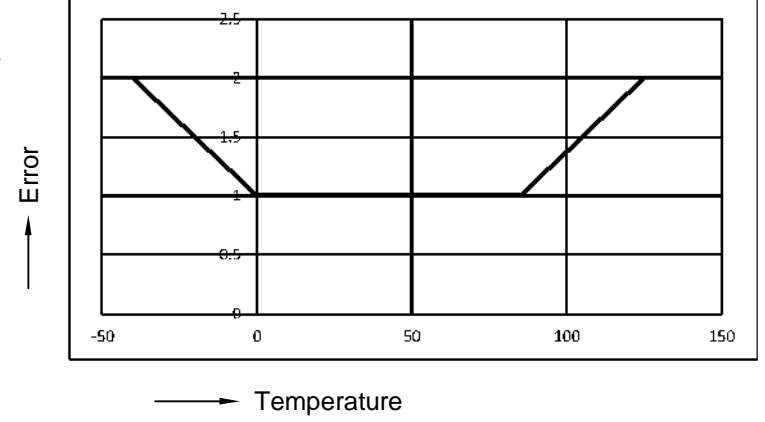

Sr. No.	Spec / Parameter	Value/Description
1	Housing & cap material	PA66 GF30% (Black)
2	PCB	FR4
3	Terminals	Brass tin plated
4	Protection Class	IP68
5	Tightening/clamping force	TBD. Tentative 30 kg.
6	Supply voltage	5 +/- 0.25 VDC
7	Max supply voltage	11 VDC
8	Output voltage range	0.5 +/- 0.04 to 4.6 +/- 0.04 VDC
9	Response time	1 ms
10	Compensated temp range	0 to 85 C
11	Accuracy	1% of FS (51 mV)
12	Power ON rise time and warm up time	10 ms
13	Offset stability	+/- 0.5% of 5.1 VDC (25 mV)
14	Operating pressure	13.3 to 120 kPa
15	Overpressure	490 kPa
16	Operating temperature	-40 to 120°C
17	Storage temperature	-40 to 130°C
18	Supply current	10 to 14 mA
19	Sink current	0.2 mA
20	Source current	-0.1 mA
21	Field strength	150 V/m
22	Ratiometric error	a) +/- 2 kPa at 120°C b) +/- 2 kPa at - 40°C c) +/- 1 kPa From 0 to +85°C

UNI-AUTOMATION (I) PVT LTD  
 TEL/FAX:+91-(020)-24420890  
 www.uniautomation.com

**MANIFOLD ABSOLUTE PRESSURE  
 SENSOR**

DATE:- 29-11-2017 SCALE:-1:1

**MODEL MAP(212)**

TOLERANCES  
 DIN-ISO 2768-1 (1991-06)  
 (TOLERANCE CLASS-MEDIUM)

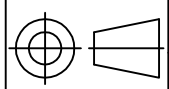

CUSTOMER DRAWING REF NO  
 NA

REV - 00

UAPL PART NO  
**199212**

CUSTOMER : STD

SHEET 2of3

### PROPOSED VALIDATION TESTING FOR MAP SENSOR

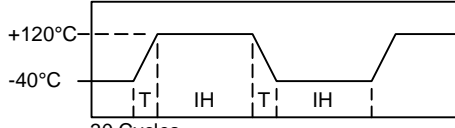
Sr.No.	TEST	UAPL SPECIFICATIONS
1	Vibration Resistance Test	1. 294 m/s <sup>2</sup> , 30G, 50-500 Hz, 6 min linear sweep 2. 3 planes -- XYZ 3. 8 hours each
2	Thermal Shock Test	Pattern  Cycles 30 Cycles
4	High Temperature Exposure Test	Temperature: 125 C Duration: 100 hours
5	Low Temperature Exposure Test	Temperature: -40 C Duration: 100 hours
6	High Humidity Test	Temperature: 60 C +/- 3C Humidity: 90 to 95% RH Duration: 200 hours
7	Water Resistance Test	Continuous spray of constant pressure of 1 bar from 500 mm distance for 50 hours with applied voltage of 5 VDC and output at fixed 2.5 VDC.

8	Drop Test	Method	Hold connector, drop freely on to concrete from 1m
		Number of Times	3
9	Over voltage Test	Method	Apply 24Vdc across terminal "A"(GND) and terminal "C" Pressure and "B" (+)Input
		Duration	1 Minute +10 Second -0 Second
10	Water Immersion Test	Water immersion of sensor and carburetor assembly: heat sensor to 110C for 2hours, then immerse in 25C water for 2 hours while measuring sensor output and noting readings.	
11	Insulation resistance	500 VDC applied between terminals and housing, 10MOhm expected value	
12	Pulse pressure (life test)	1 Million pressure cycles --- 1 cycle is 13.3 kPa to 120 kPa.	
13	Overpressure	1000 cycles --- 1 cycle is 13.3 kPa to 490 kPa	
14	Burst pressure	1 cycle --- 13.3 kPa to pressure until sensor fails (700 kPa max.) --- for 5 sensors	

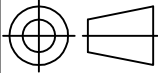
UNI-AUTOMATION (I) PVT LTD TEL/FAX:+91-(020)-24420890 www.uniautomation.com		<b>MANIFOLD ABSOLUTE PRESSURE SENSOR</b>	
DATE:- 29-11-2017		SCALE:-1:1	
TOLERANCES DIN-ISO 2768-1 (1991-06) (TOLERANCE CLASS-MEDIUM)		UAPL PART NO <b>199212</b>	
		CUSTOMER DRAWING REF NO NA	REV - 00
		CUSTOMER : STD	SHEET 3of3